

Adept Cobra™ s800



Specifications

Reach	800 mm
Payload (max)	2 kg (rated) 5.5 kg (max)
Joint 4 inertia (max)	450 kg-cm ²
Downward Push Force	30 kgf
Adept Cycle	
Burst Mode	0.54 sec (2 kg)
Sustained	0.54 sec (2 kg)
Joint Range	
Joint 1	± 105°
Joint 2	± 157.5°
Joint 3	210 mm
Joint 4	± 360°
Joint Speeds	
Joint 1	386°/sec
Joint 2	720°/sec
Joint 3	1100 mm/sec
Joint 4	1200°/sec
Repeatability	
XY	± 0.017 mm
Z	± 0.003 mm
Theta	± 0.019°
Pass-Through User Connections	
Electrical	24 (12 twisted pairs)
Pneumatic	6 mm (x2) 4 mm (x3)
DeviceNet	
Digital I/O Channels	12 inputs 8 outputs (included) 4 solenoid outputs (end of arm)
Weight	43 kg
Environmental Requirements	
Ambient temperature	5 - 40 °C
Humidity range	5 - 90 % (non condensing)
Power Requirements for SmartController	24VDC (± 10%), 120W (6A) 200V to 240V AC, 1-phase, 50/60Hz (10A) User-Supplied
CE and UL compliant	

The Adept Cobra s800 is a high-performance robot system for mechanical assembly, material handling, packaging, machine tending, screwdriving, and many other operations requiring fast and precise automation. Adept Cobra s-series robots are available with 600 mm and 800 mm reach.

Product Features and Benefits

- Absolute encoders make for easy calibration
- High-resolution encoders provide high precision and superior slow-speed following
- High-efficiency motors deliver high performance with more torque per amp
- Low-inertia harmonic drives provide maximum acceleration
- Temperature sensors on the motors and amplifiers maximize performance and reliability
- 8 kHz servo update for improved path following and control
- Integrated temperature sensors monitor heat in servo motors to prevent damage
- Diagnostics display on robot enables faster troubleshooting
- Easy replacement of electronic sub-assembly in the robot reduces MTTR

Adept Cobra™ s800

Dimensions Adept Cobra s800 (mm)

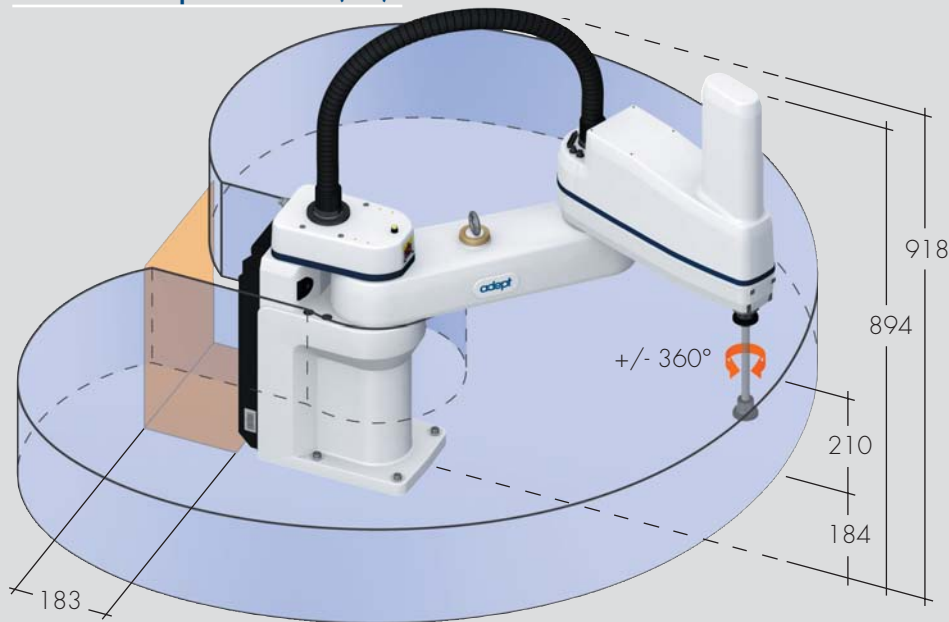

- Work Envelope: Radius 800 mm
Inner Limit: Radius 164 mm
Height: 210 mm

- Required clearance to open AIB Chassis

Dimensions Flange (mm)

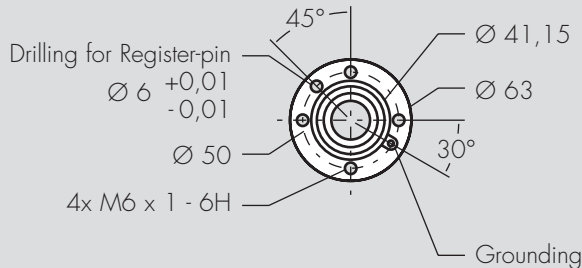

Dimensions foot plate (mm)

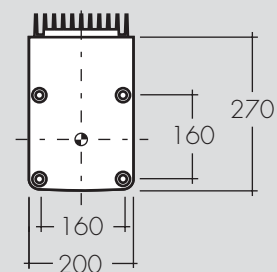

The Adept Cobra s800 system includes the following:

- Adept Cobra s800 Robot
- Adept SmartController CX (with software installed)
- Front Panel with E-Stop
- AdeptWindows Software
- Network File Server (NFS) software
- Ethernet TCP/IP capability
- User Documentation

- J4 High resolution
- Stop on digital input
- Also available in Ceiling Mounted version (Cobra s800 Inverted)

Downloads:

- Download CAD files from www.adept.com using the following download ID:
Adept Cobra s800 Robot 500008

Optional Peripherals:

- T1 Pendant
- IO Blox (8 digital input & 8 digital output channels)
- sDIO (32 digital input & 32 digital output channels)
- AdeptSight or sAVI Vision system
- Hardstop kit
- Solenoid kit
- Dual Configuration
- IP65 option



Adept Technology, Inc. 3011 Triad Drive, Livermore, CA 94551

Tel: 925-245-3400 Fax: 925-960-0452 Email: info@adept.com

www.adept.com

Specifications subject to change without notice.

©2007 Adept Technology, Inc. All rights reserved. Adept and the Adept logo are registered trademarks, and the Adept Cobra is a trademark of Adept Technology, Inc. All other trademarks are the property of their respective holders. ACs800DS0707