

## IRB 360 FlexPicker®

Greater flexibility in a compact footprint



For nearly 15 years, ABB's IRB 360 FlexPicker has been the leader in state-of-the-art high speed robotic picking and packing technology. Compared to conventional hard automation, the IRB 360 offers much greater flexibility in a compact footprint while maintaining accuracy and high payloads.

ABB's IRB 360 family of robots, more commonly known as the FlexPicker, are capable of the fastest picking applications and have been optimized for packing applications. The robot has outstanding motion performance with the shortest cycle times, precision accuracy, and high payloads.

The IRB 360 family includes variants with payloads of 1 kg, 3 kg, 6 kg, and 8 kg and reaches of 800 mm, 1130 mm and 1600 mm—meaning there is an IRB 360 for almost every need.

Featuring outstanding motion control, short cycle times, and precision accuracy, an IRB 360 can operate at very high speeds in anything from narrow to wide spaces with very tight tolerances. Every FlexPicker also benefits from a re-engineered tool flange which can accommodate larger grippers, allowing for efficient handling of flow wrapped products at high speeds from an indexing belt.

### Food handling applications

A stainless option for food handling applications is IP69K validated so that it can be washed down with industrial detergents and high pressure hot water. This variant is also designed with smooth and easy to rinse-off surfaces and lubricant free joints that are resistant to most corrosives.

### Software and controls

Setting up an application becomes easy using PickMaster™ software which has evolved into an invaluable help for integrators and users. It simplifies vision configuration and offers the application tools needed for efficient high speed picking.

The reliable, market leading IRC 5 controller is also an integral part of the FlexPicker robot family. The IRC 5 with TrueMove™ and QuickMove™ guarantees high speeds and path following facilities which allows these robots to track fast moving conveyor belts with extreme accuracy.

The IRC 5 also is available in a panel-mounted version that offers substantial space savings and easy integration into machines and production lines.

### Features

- High speed flexibility
- High capacity – up to 8 kg payload
- Hygienic design for washdown applications
- Superior tracking performance
- Integrated vision software
- Integrated control of indexing belts

Specifications			
Robot version	Handling capacity	Diameter	No. Axes
IRB 360-1/800	1 kg	800 mm	4
IRB 360-1/1130*	1 kg	1130 mm	3/4
IRB 360-3/1130	3 kg	1130 mm	3/4
IRB 360-1/1600	1 kg	1600 mm	4
IRB 360-6/1600	6 kg	1600 mm	4
IRB 360-8/1130	8 kg	1130 mm	4
Supplementary load	on upper arm		350 g
	on lower arm		350 g
Integrated signal supply	12 poles 50V, 250mA		
Integrated vacuum supply	Max. 7 bar/max vacuum 0.75 bar		

\* Tested by IPA, all axes

### Physical

Robot mounting	Inverted
Weight	120 kg (Standard & wash down)
	145 kg (Stainless wash down)

### Performance

Position repeatability	0.1 mm	
Angular repeatability	Standard & stainless axis 4	0.4°
	Wash-down axis 4	1.5°

### Cycle times

	0.1 kg	1 kg	3 kg	6 kg	8 kg
25/305/25 (mm)					
IRB 360-1/1130	0.30	0.36			
IRB 360-3/1130	0.40	0.40	0.52		
IRB 360-8/1130		0.38	0.42		0.60
IRB 360-1/1600	0.35	0.40			
IRB 360-6/1600		0.43	0.48	0.60	
90/400/90 (mm)					
IRB 360-1/1130	0.44	0.51			
IRB 360-3/1130	0.60	0.60	0.75		
IRB 360-8/1130		0.55	0.65		0.92
IRB 360-1/1600	0.50	0.54			
IRB 360-6/1600		0.57	0.63	0.80	

\*\* The cycle times are measured under real conditions, but may vary depending on the actual application. Please use RobotStudio or real cycle tests to verify actual cycle time.

### Electrical connections

Supply voltage	200-600 V, 60 Hz	
Transformer rating	7.2 kVA	
Power consumption	type of movement	IRB 360/1
	typical pick & place cycle (1 kg)	0.477 kW

### Conveyor tracking

	speed (mm/s)	repeatability
Constant conveyor	200	1.0 mm
	350-750	1.5 mm
	800-1400	5.0 mm
Start/stop conveyor	500 (start/stop in 0.2 sec)	3.5 mm
Indexing conveyor control	3.5 g acceleration/ deceleration	2.0 mm

\*\*The tracking is measured under real conditions with IRB 360-1/1130 & PickMaster. The figures may vary depending on the actual robot max. speed & acceleration in relation to the application demands.

### Environment

Ambient temperature	IRB 360 manipulator	±0°C to +45°C
	Relative humidity	Max. 95 %
Noise level	< 70 dB(A)	
Safety	Double circuits with supervision, emergency stops & safety functions, 3 position enabling device	
Emission	EMC/EMI shielded	
Clean room options axis 4	Standard	Clean room 7
	Wash down	Clean room 5*
	Stainless	Clean room 5*
	Option	Collision detection

\* Certified by IPA

\*\* Data and dimensions may be changed without notice

### Working range

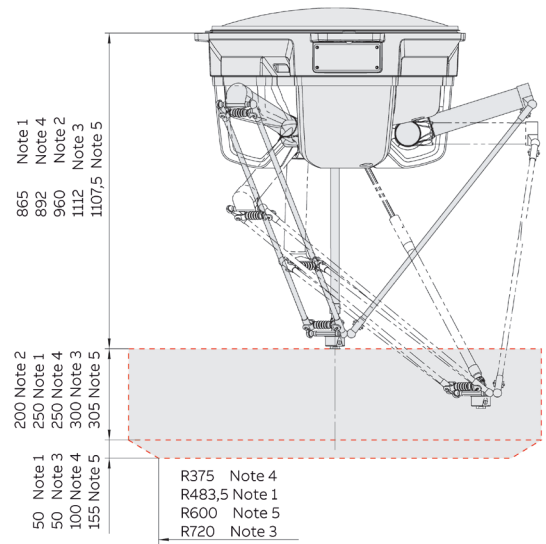

Note 1: IRB 360-1/1130 and IRB 360-3/1130  
 Note 2: IRB 360-1/800  
 Note 3: IRB 360-1/1600  
 Note 4: IRB 360-8/1130  
 Note 5: IRB 360-6/1600

ABB AB Robotics  
 Hydrovägen 10 SE-721 36  
 Västerås, Sweden  
 Phone: +46 21325000

ABB Engineering (Shanghai) Ltd.  
 No. 4528, Kangxin Highway,  
 Pudong New District,  
 Shanghai, 201319, China  
 Phone: +86 21 6105 6666

We reserve the right to make technical changes or modify the contents of this document without prior notice. With regard to purchase orders, the agreed particulars shall prevail. ABB does not accept any responsibility whatsoever for potential errors or possible lack of information in this document.

We reserve all rights in this document and in the subject matter and illustrations contained therein. Any reproduction, disclosure to third parties or utilization of its contents – in whole or in parts – is forbidden without prior written consent of ABB.  
 Copyright © 2017 ABB  
 All rights reserved