

## IRB 6790

Expert for washing and cleaning in harsh environments

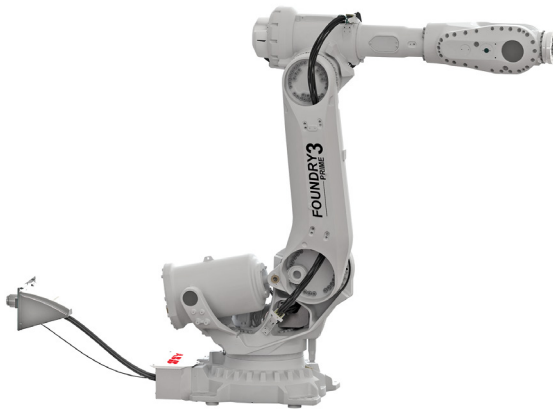

The market leading robot with lowest total cost of ownership in the most demanding washing and cleaning applications. It is designed for high reliability in harsh environments and reduces maintenance costs by up to 60%.

### Supports applications in the toughest environments

ABB's IRB 6790 Foundry Prime robot is designed for high-pressure water jet cleaning, washing and similar applications in harsh industrial environments with 100% humidity. Leveraging more than 13 years of industry experience, ABB developed its third-generation Foundry Prime robot aimed at increasing reliability and system uptime, while reducing maintenance costs.

The robot is available in two variants – one with a 205 kg payload with 2.80 m reach, and one with a 235 kg payload and 2.65 m reach.

### Unrivalled flexibility for increased productivity

The IRB 6790's high flexibility allows different part geometries to be cleaned in the same cell with zero changeover time. This supports mass customization for automotive manufacturers as well as original equipment manufacturers and their tier suppliers. In addition to increased flexibility and productivity, this solution provides faster speeds and on average a 5% shorter cycle time.

The robot design is focused on delivering reliability, improved system uptime, and optimized maintenance for convenient serviceability, which reduces the total cost of ownership by 60%.

### Enhanced protection from water and dust

IP69-rated for protection from water and dust ingress, in addition the third-generation Foundry Prime robot provides enhanced protection from heat, cleaning pressure, chemicals, and dirt typically found in harsh and wet environments without the need for an additional complex protective covering. Because cleaning or washing processes are performed using detergents that can reach a pH level of 10, the Foundry Prime robot is built with a high chemical tolerance. Additionally, all external robot surfaces are either coated or in stainless steel to protect against corrosion. The Foundry Prime 3 can withstand 100% humidity and the water vapor of a typical cleaning application to ensure a long product lifecycle under aggressive cleaning operations.

### Key Features and Benefits

- Stainless steel and plated surfaces to ensure corrosion protection.
- All movable sealing joints in stainless steel.
- Higher thermal and chemical resistance with durable Viton® seals.
- All electrical encapsulations, wrist and balancing unit pressurized and supervised.
- Cable glands made for wet environment.
- Compatible with pH levels of up to 10.
- Protection level IP 69.
- All warning and instruction signs are etched to withstand the environment.

## Specification

Robot version	Reach (m)	Handling capacity (kg)*	Center of gravity (kg)	Wrist torque (Nm)
IRB 6790-235/2.65	2.65	235	300	1324
IRB 6790-205/2.80	2.80	205	300	1263
Number of axes	6			
Protection	IP69, Foundry Prime 3			
Mounting	Floor			
Controller	IRC5 Single cabinet IRC5 PMC Panel mounted controller			

\*Extra loads can be mounted on all variants. The upper arm can handle an additional load of 50 kg and the frame on axis 1 can handle an additional load of 250 kg.

## Performance (according to ISO 9283)

	Position repeatability	Path repeatability
IRB 6790-235/2.65	0.05 mm	0.08 mm
IRB 6790-205/2.80	0.05 mm	0.08 mm

## Technical information

### Electrical Connections

Supply voltage	200-600 V, 50/60 Hz
Power consumption	ISO-Cube 2.7 kW

### Physical

Robot base	1009 x 745 mm
Robot weight	
IRB 6790-235/2.65	1260 kg
IRB 6790-205/2.80	1270 kg

### Environment

Relative humidity	100%
Noise level	Max. 71 dB
Safety	Double circuits with supervisions, emergency stops and safety functions. 3-position enable device

Emission	EMC/EMI shielded
----------	------------------

Data and dimensions may be changed without notice.

## Movement

Axis movement	Working range	Axis max. speed
Axis 1 Rotation	+170° to -170° Option: +220° to -220°	100 °/s
Axis 2 Arm	+85° to -65°	90°/s
Axis 3 Arm	+70° to -180°	90°/s
Axis 4 Wrist	+300° to -300°	170 °/s
Axis 5 Bend	+130° to -130°	120 °/s
Axis 6 Turn	+360° to -360°	190 °/s

### Working range, IRB 6790-235/2.65

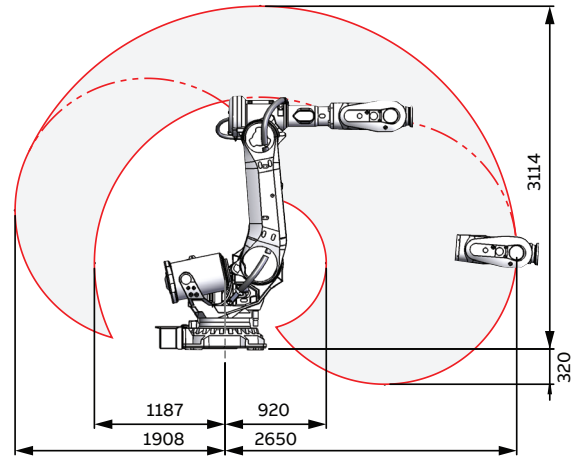

### Working range, IRB 6790-205/2.80

